

JP75

ELECTRIC TOWBARLESS TUG

CRITICAL DIMENSIONS

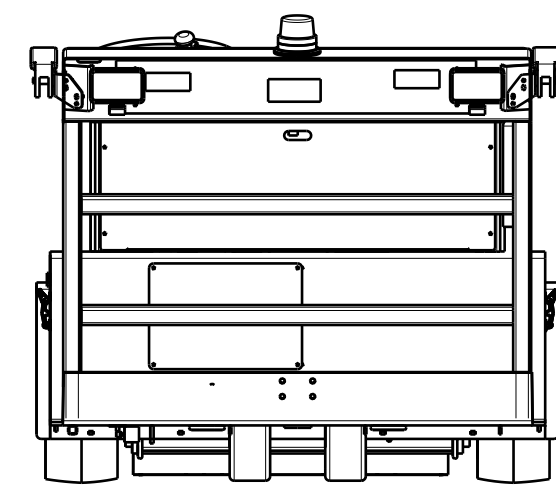
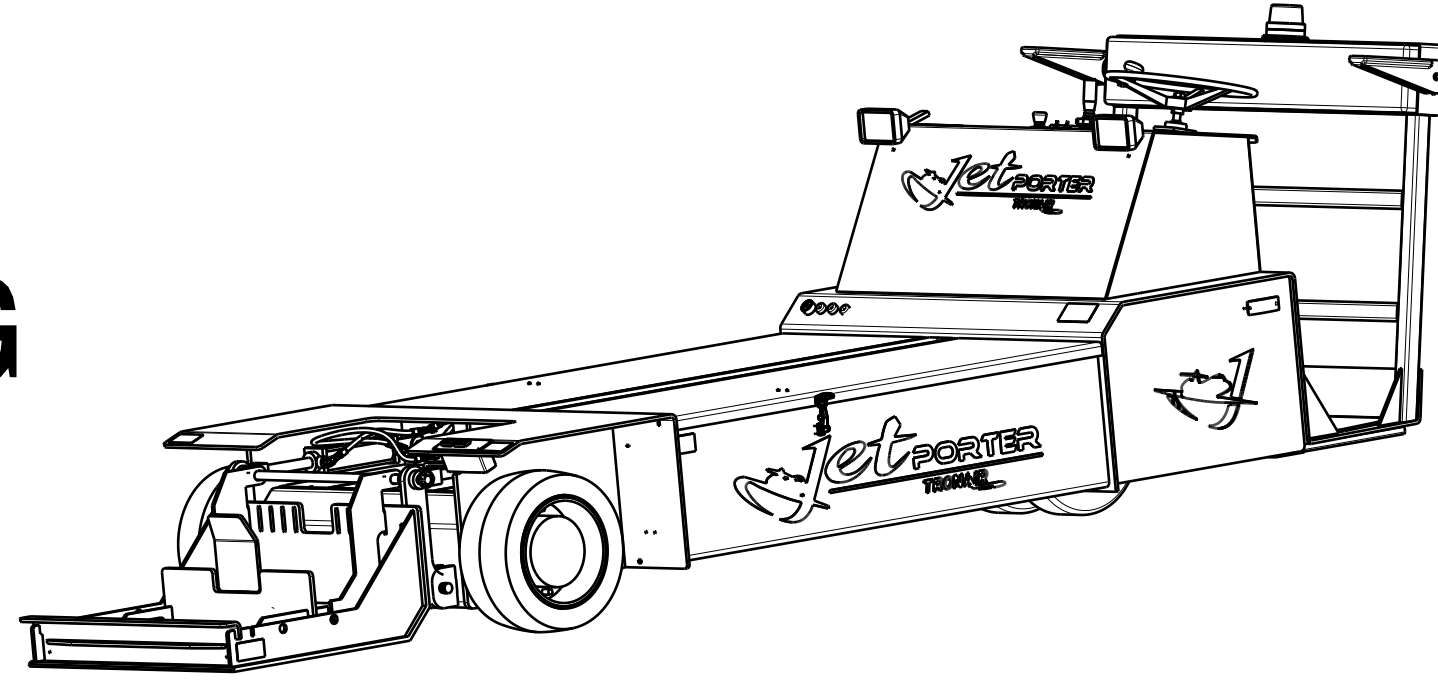

REAR VIEW

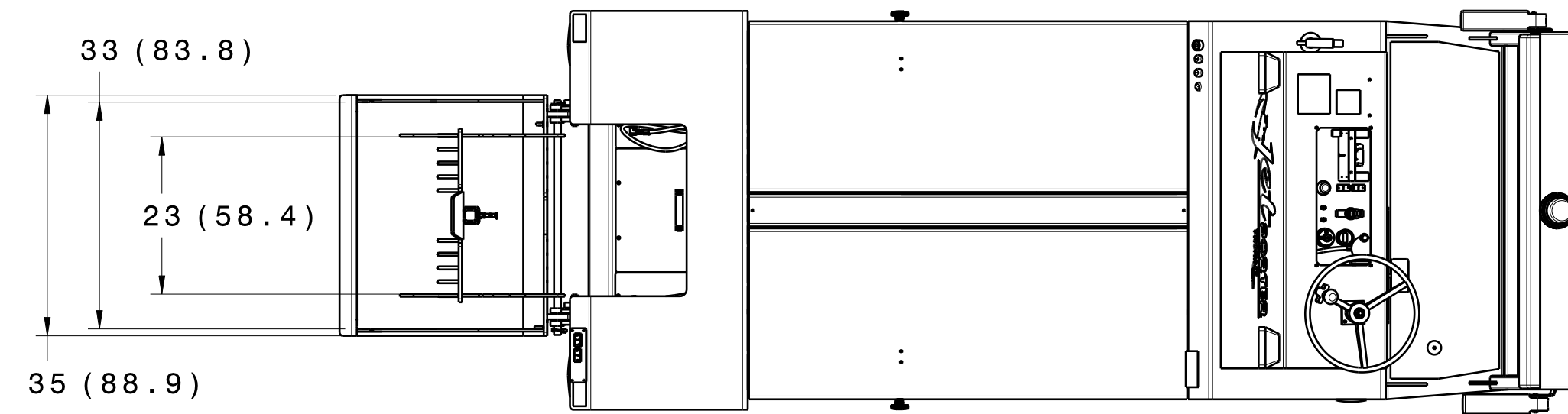

TOP VIEW

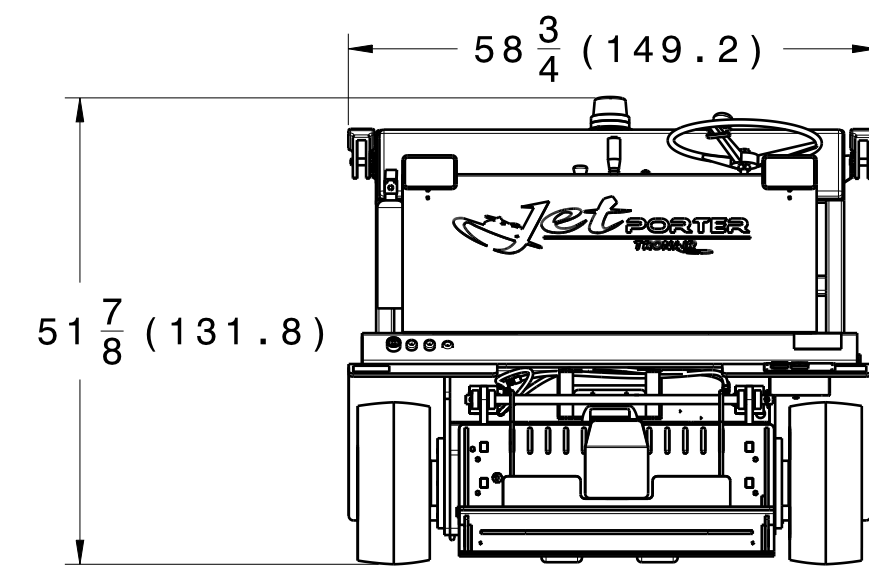

FRONT VIEW



LEFT SIDE VIEW
5 3/8 (13.7)

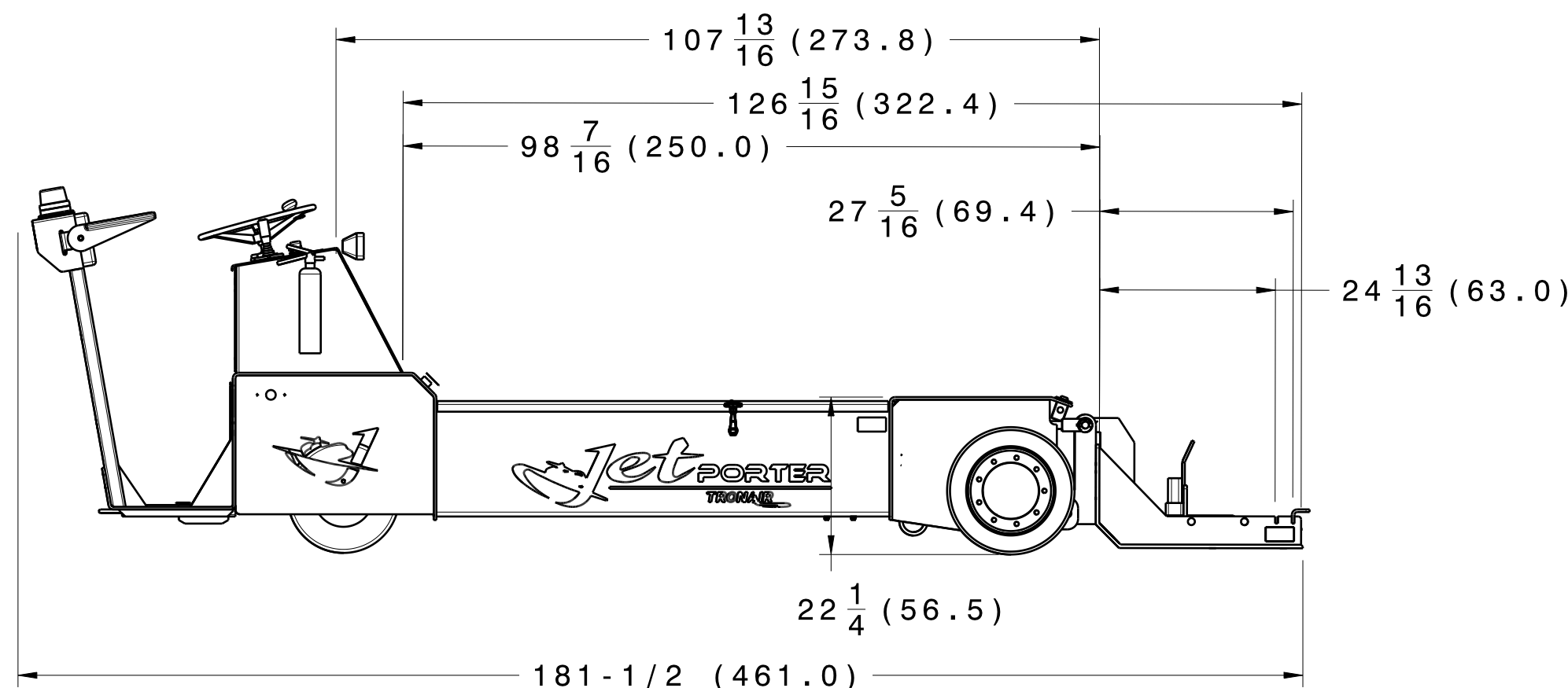

RIGHT SIDE VIEW
181-1/2 (461.0)

GENERAL DESCRIPTION:

MAX TOWING CAPACITY:	75,000 LBS (34019 KG)
OVERALL HEIGHT:	51 7/8" (131.8 CM)
OVERALL WIDTH:	58 3/4" (149.2 CM)
OVERALL LENGTH:	181 1/2" (461.0 CM)
WEIGHT:	5,700 LBS (2585 KG)W/BATT 4,020 LBS (1823 KG) W/O BATT
FINISH:	POWDER COAT TRONAIR BLUE
CRADLE CAPACITY:	7,500 LBS (3402 KG)
MAX CRADLE TIRE WIDTH:	23" (58.4 CM)
STEERING TIRES:	(2) 4.00 X 8
DRIVE TIRES:	(2) 18 X 8 X 12 1/8
GROUND CLEARANCE:	5 3/8" (13.7 CM)
DECK HEIGHT:	22 1/4 (56.5 CM)
HEIGHT:	51 7/8" (131.8 CM)
CRADLE DEPTH:	27 5/16" (69.4 CM)
CRADLE WIDTH:	35" (88.9 CM)
INSIDE CRADLE WIDTH:	33" (83.5 CM)
CRADLE LIFT HEIGHT:	7" (17.8 CM)

POWER

BATTERY TYPE:	SIXTEEN – 6 VOLT DEEP CYCLE
CHARGE TIME FULL DISCHARGE:	8 HOUR AVERAGE
CHARGER:	208/240/480 VOLTS AC, 36/31.4/16 AMPS, SINGLE PHASE

INDICATE REQUIRED FREQUENCY:
OR
JP-204-50 (50 HERTZ)
JP-204-60 (60 HERTZ)

CAPACITY

EMPTY SPEED:	7 MPH
FULL LOAD SPEED:	3 MPH
MOTOR HORSEPOWER:	(2) 8 HP

